



# BRIKA

## B-B10T-V

ROBUST DESIGN  
HIGH QUALITY STAINLESS STEEL

# ELECTRIC COMBI OVEN BISTROT 10T VISION



Intertek

- 6 pre-set languages
- Up to 10 steps cooking
- Pre-loaded & online cookbook + USB port for custom preset programs mode

Ask about the **left** hinge door option!



- 7" display touch screen
- Automatic cooking control (preheating & delayed start programming)
- Manual mode option + manual steam injection
- Multi-timer function for multiple & mixed cooking
- Fan inversion, speed control and motor break
- 5 Fan speeds and semi-static cooking

Blue LED light for chamber cleaning check

**BakePOINT**  
multipoint core probe

**BakeSTEAM**  
Steam control in percentages

**BakeDRY**  
Automatic chimney opening

**BakeCLEAN**  
automatic washing system

### 9 Cooking modes

- Convection
- Steam
- Mixed Convection + Steam
- Mixed Convection + dry air
- Core probe cooking
- Delta cooking
- Multi-level cooking
- Vacuum (optional)
- Pasteurization (optional)

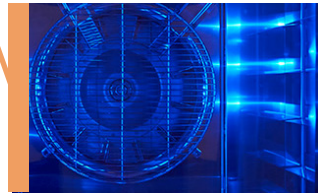
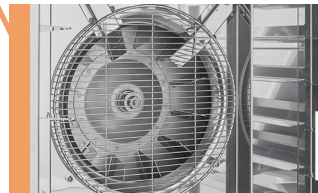

Accommodates bunpans **18" x 26"** & smaller:  
15" x 21"    13" x 18"    gastronom 2/3

# B-B10T-V

Dimensions [w×d×h]	33 <sup>1</sup> / <sub>2</sub> " x 36 <sup>5</sup> / <sub>8</sub> " x 45 <sup>1</sup> / <sub>4</sub> "
Oven interior [w×d×h]	20 <sup>7</sup> / <sub>8</sub> " x 28" x 35"
Rack Guides	10
Max Temp	270°C / 520°F
Weight	NET: 247lbs BOX: 291lbs
Package [w×d×h]	36 <sup>1</sup> / <sub>4</sub> " x 39 <sup>3</sup> / <sub>8</sub> " x 51 <sup>1</sup> / <sub>8</sub> "

## POWER SUPPLY

Power 15 KW

### Voltage

208V / 1PH	- 72.2 AMP
208V / 3PH	- 41.7 AMP
240V / 1PH	- 62.5 AMP
240V / 3PH	- 36.1 AMP

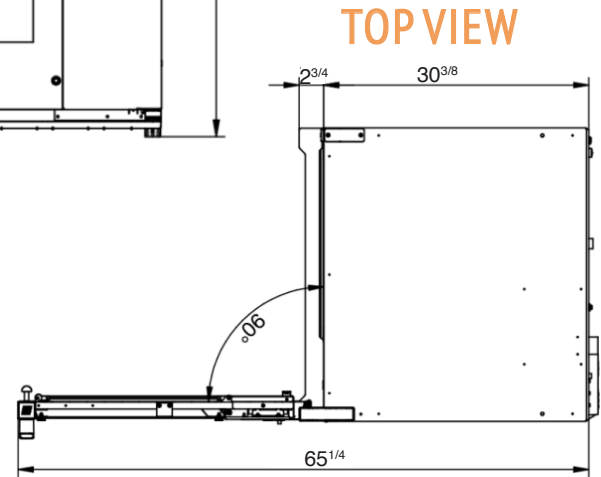
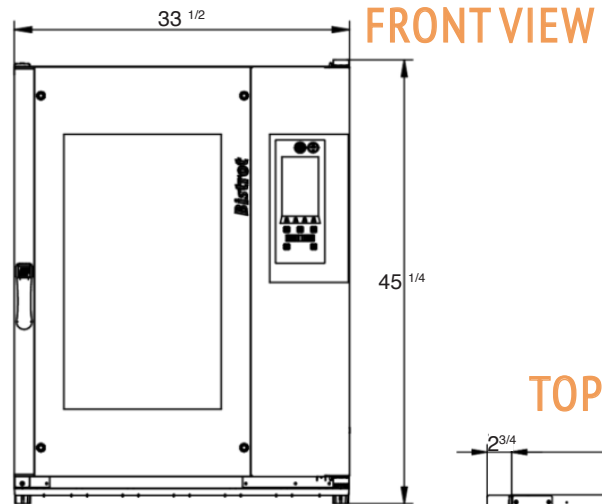
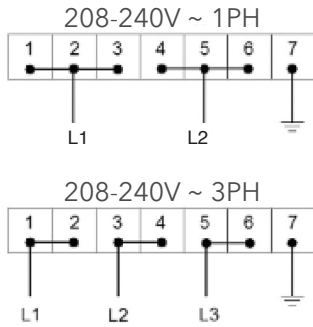

## ADD-ONS & OPTIONS

- BakeHIN vacuum core probe
- BakeNET network connection
- Ventilation Hood
- Pasteurization kit
- Oven racks

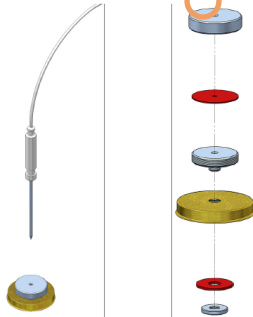

STAINLESS  
STEEL BUN  
PAN RACK



STAINLESS STEEL  
EQUIPMENT STAND



ASSEMBLY/SUPPORT



MORE PRODUCTS



## SAFETY

Keep combustibles a minimum of 12" away from the equipment. Keep a clearance of 4" at the rear.

 We're on social media! 